

ISS.	AMEND	DATE
1	S14 DET1	11/2/80
2	S14 DET2	19/6/90
3	REDRAWN GOLD ADDED	13/12/02

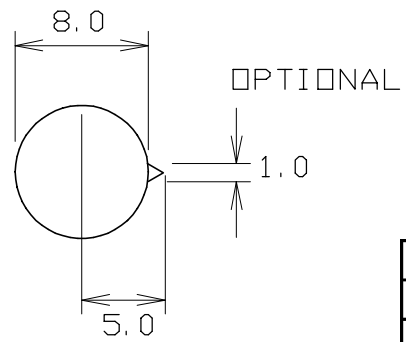

PANEL MOUNTING HOLE

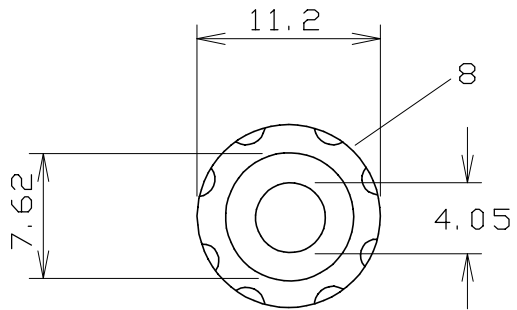
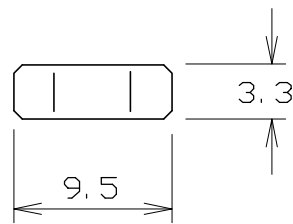
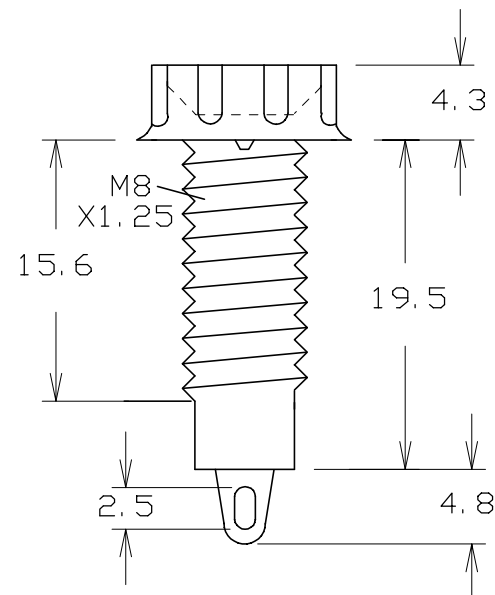

BRASS FIXING NUT CL 1465

VARIANTS		
P/No	COLOUR	FINISH
CL 1450	BLACK	
CL 1450G	BLACK	GOLD
CL 1452	RED	
CL 1452G	RED	GOLD
CL 1454	YELLOW	
CL 1456	BLUE	
CL 1458	GREY	
CL 1460	GREEN	
CL 1462	BROWN	
CL 1464	WHITE	

RATED @ 10A MAX

RoHS ✓ COMPLIANT
TOLERANCE NO DEC. PLACE ± 0.50 1 DEC. PLACE ± 0.20 2 DEC. PLACE ± 0.10 HOLE DIA. ± 0.10 ANGLES ± 1/2° UNLESS OTHERWISE STATED
WHERE USED F.R.
SCALE N.T.S.

DIMENSIONS IN MILLIMETERS UNLESS OTHER WISE STATED. WORK TO DIMENSIONS. DO NOT SCALE DRAWING. 3rd ANGLE PROJECTION. REMOVE ALL BURRS. IF IN DOUBT ASK.

Cliff Electronic Components Ltd. 76 Holmethorpe Ave., Holmethorpe Ind. Estate, Redhill, Surrey, RH1 2PF, England Tel: 01737-771375 Fax: 01737-766012	MATERIAL	POLYPROPYLENE / NiAg (18% Ni)	TITLE		4mm PANEL SOCKET S14
	FINISH	AS MOULDED/AS ROLLED (GOLD SPECIAL)	DRWG. No.	CL1450	FORM: A4DRWGH
DRAWN	CAMJ	APPD.	RWT		